



# VOLUNTARY RECALL CAMPAIGN

Classification: BT24-004	Reference: NTB24-042	Date: August 6, 2024
-----------------------------	-------------------------	-------------------------

## VOLUNTARY SAFETY RECALL CAMPAIGN 2024 FRONTIER; FRONT RH COMBINATION LAMP

**CAMPAIGN ID #:** PD121  
**APPLIED VEHICLES:** 2024 Frontier (D41)

**Check Service COMM or Dealer Business Systems (DBS)  
National Service History to confirm campaign eligibility.**

### INTRODUCTION

Nissan is conducting this voluntary safety recall campaign on certain specific model year 2024 Frontier vehicles to inspect and if necessary, replace the front passenger (RH) combination lamp. This service will be performed at no charge to the customer for parts or labor.

### IDENTIFICATION NUMBER

Nissan has assigned identification number PD121 to this campaign. This number must appear on all communication and documentation of any nature dealing with this campaign.

### DEALER RESPONSIBILITY

It is the dealer’s responsibility to check Service COMM or Dealer Business Systems (DBS) National Service History for the campaign status on each vehicle falling within the range of this voluntary safety recall which for any reason enters the service department. This includes vehicles purchased from private parties or presented by transient (tourist) owners and vehicles in a dealer’s inventory. **Federal law requires that new vehicles in dealer inventory which are the subject of a safety recall must be corrected prior to sale. Failure to do so can result in civil penalties by the National Highway Traffic Safety Administration.** While federal law applies only to new vehicles, Nissan strongly encourages dealers to correct any used vehicles in their inventory before they are retailed.

Bulletins are intended for use by qualified technicians, not 'do-it-yourselfers'. Qualified technicians are properly trained individuals who have the equipment, tools, safety instruction, and know-how to do a job properly and safely. **NOTE:** If you believe that a described condition may apply to a particular vehicle, DO NOT assume that it does. See your Nissan dealer to determine if this applies to your vehicle.

## SERVICE PROCEDURE

1. Open the hood.



Figure 1

2. Locate the front passenger (RH) combination lamp.

**HINT:** The combination lamp shown in Figure 2 is an LED combination lamp. A Halogen combination lamp is similar.

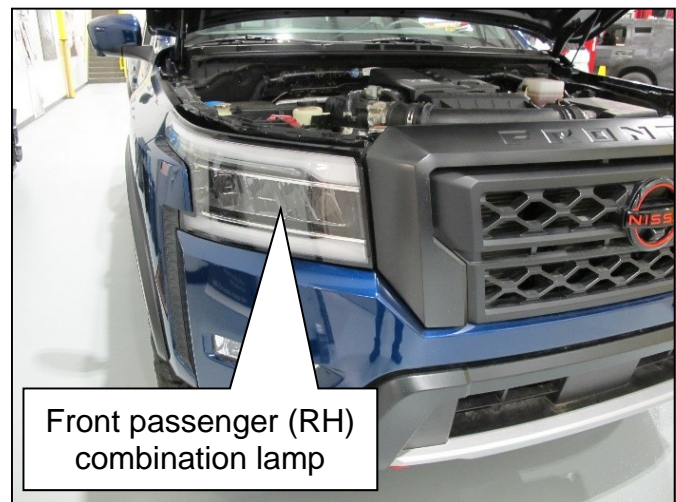

Figure 2

3. Locate the inspection area on the top of the front passenger (RH) combination lamp.
  - The inspection area is outlined in GREEN in Figure 3.

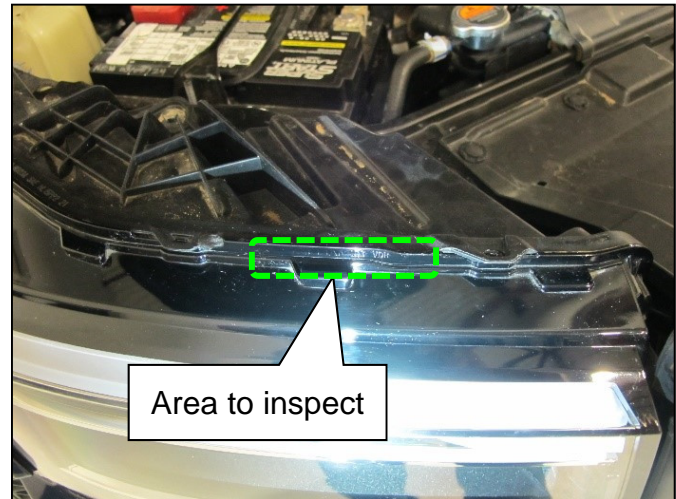

Figure 3

4. Visually locate the “NISSAN DOT VOR” mold marking (Figure 4).

**HINT:** Ensure the inspection area is clean and use a light source as needed.

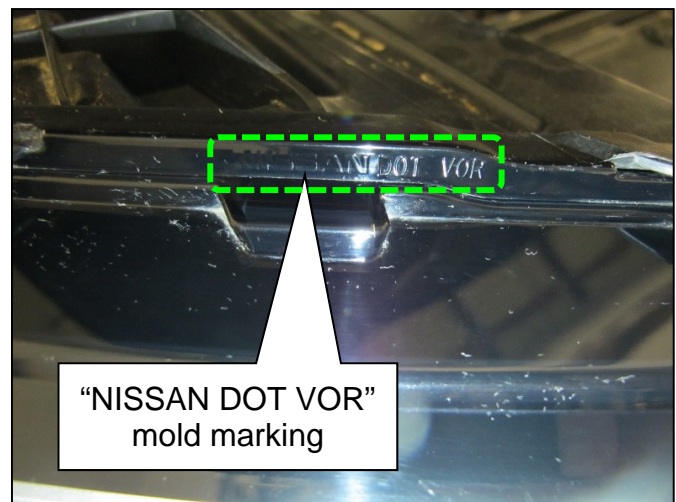

Figure 4

5. Is the “VOR” mold marking present AND legible on the front passenger (RH) combination lamp, as shown in Figure 5?

**HINT:** When inspecting for the “VOR” mold marking, “NISSAN DOT” mold marking should be present if inspecting the correct location of the combination lamp.

**YES:** The “VOR” mold marking is present AND is legible on the front passenger (RH) combination lamp, as shown in Figure 5. Front passenger (RH) combination lamp replacement is NOT required. Skip to step 10 on page 6.

**NO:** The “VOR” mold marking is NOT present or is NOT legible on the front passenger (RH) combination lamp, as shown in Figure 6. Continue to step 6 on page 5 to replace the front passenger (RH) combination lamp.



6. Replace the front passenger (RH) combination lamp.
  - Refer to the ESM: **DRIVER CONTROLS > EXTERIOR LIGHTING SYSTEM > REMOVAL AND INSTALLATION > FRONT COMBINATION LAMP > Removal and Installation**
    - Tighten the front passenger (RH) combination lamp bolts to 5.0 N•m (0.51 kg-m, **44 in-lb**)

**HINT:** The front driver (LH) combination lamp is shown in Figure 7, the front passenger (RH) combination lamp is similar.

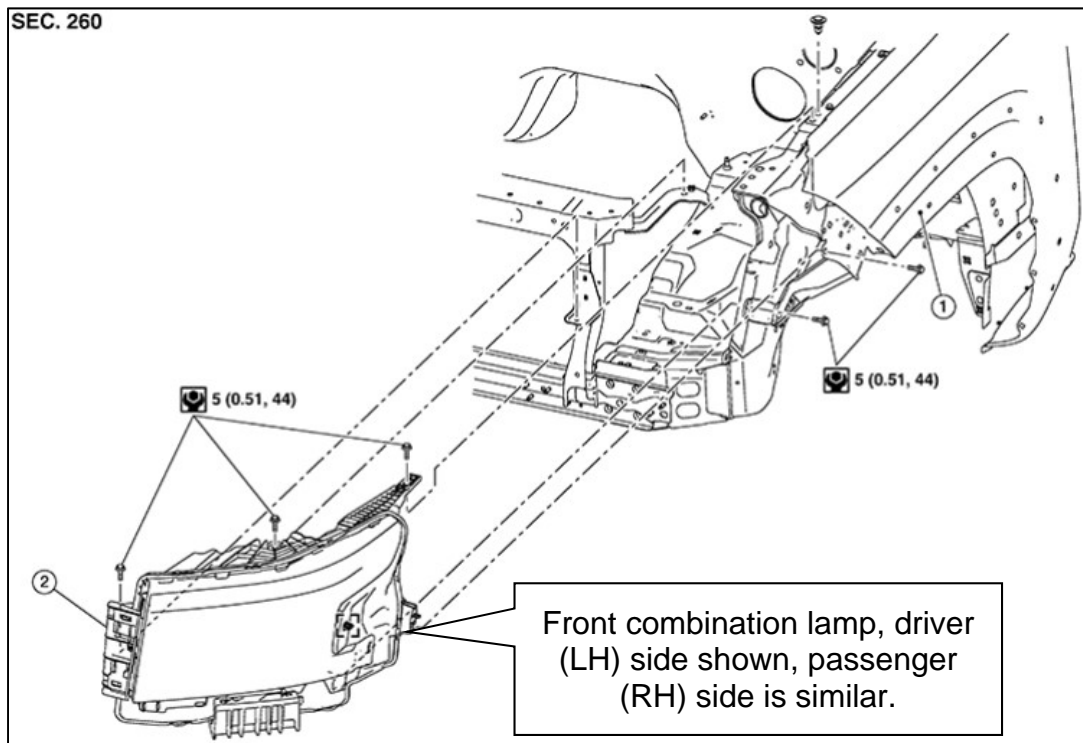

Figure 7

7. If equipped with ICC, continue to step 8. If NOT equipped with ICC, skip to step 9 on page 6.
8. If equipped with ICC, perform ICC system action test to check that the ICC system operates normally.
  - Refer to the ESM **CRUISE CONTROL & DRIVER ASSISTANCE > CRUISE CONTROL SYSTEM > ICC > BASIC INSPECTION > ACTION TEST > Work Procedure**

**CAUTION**

To help reduce risk of minor or moderate personal injury and/or property damage:

- Always drive safely when performing the action test.
- Never set the cruise speed exceeding the posted speed limit.

9. On all models, start the engine and use the combination switch to verify operation of the following:

- Daytime Running Lamp operation (Parking brake must be released)
- Passenger (RH) side turn signal operation
- Headlamp operation (Low and High beam)
- Passenger (RH) side parking lamp operation
- Passenger (RH) side marker lamp operation

10. Close the hood.



Figure 8

## PARTS INFORMATION

DESCRIPTION	PART NUMBER	QUANTITY
HEADLAMP ASSY – RH (Halogen)	26010-9BU0A	1 If needed
HEADLAMP ASSY – RH (LED)	26010-9BU0D	1 If needed

## CLAIMS INFORMATION

Submit a “CM” line claim using the following claims coding:

CAMPAIGN (“CM”) ID	MODEL	DESCRIPTION	OP CODE	FRT
PD121	All	Inspect for “VOR” Mold Marking (OK Condition)	PD1210	0.2
	All except PRO-X and PRO-4X	Inspect for “VOR” Mold Marking (No Good Condition) And Replace Passenger (RH) Combination Lamp (Without AVM)	PD1211	1.0
		Inspect for “VOR” Mold Marking (No Good Condition) And Replace Passenger (RH) Combination Lamp (With AVM)	PD1212	1.3
	PRO-X and PRO-4X only	Inspect for “VOR” Mold Marking (No Good Condition) And Replace Passenger (RH) Combination Lamp (Without AVM)	PD1213	1.3
		Inspect for “VOR” Mold Marking (No Good Condition) And Replace Passenger (RH) Combination Lamp (With AVM)	PD1214	1.5

## AMENDMENT HISTORY

PUBLISHED DATE	REFERENCE	DESCRIPTION
August 6, 2024	NTB24-042	Original bulletin published